

**Makita**<sup>®</sup>

## Angle Grinder

**100 mm 9520NB**

**115 mm 9521NB**

**125 mm 9522NB**

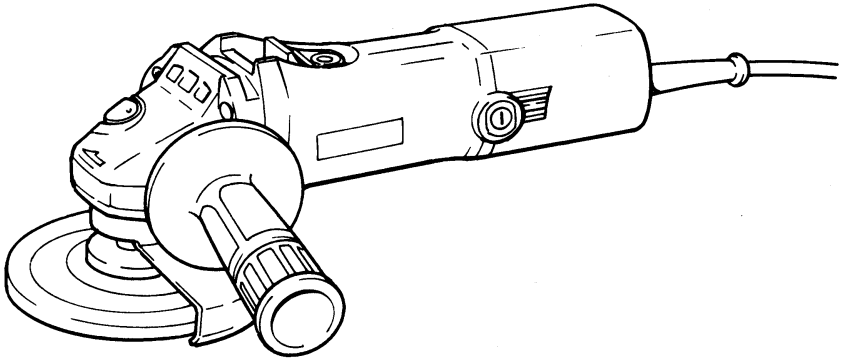

**DOUBLE  
INSULATION**

## SPECIFICATIONS

Model	9520NB	9521NB	9522NB
Depressed center wheel diameter .....	100 mm	115 mm	125 mm
No load speed (min <sup>-1</sup> ) .....	12,000	12,000	9,500
Overall length .....	262 mm	262 mm	262 mm
Net weight .....	1.3 kg	1.3 kg	1.3 kg

- Due to our continuing program of research and development, the specifications herein are subject to change without notice.
- Note: Specifications may differ from country to country.

### Power supply

The tool should be connected only to a power supply of the same voltage as indicated on the nameplate, and can only be operated on single-phase AC supply. They are double-insulated in accordance with European Standard and can, therefore, also be used from sockets without earth wire.

### Safety hints

For your own safety, please refer to the enclosed safety instructions.

## For European countries only

### Noise And Vibration Of Model

#### 9520NB/9521NB

The typical A-weighted sound pressure level is 84 dB (A).

The noise level under working may exceed 85 dB (A).

– Wear ear protection. –

The typical weighted root mean square acceleration value is not more than 2.5 m/s<sup>2</sup>.

### Noise And Vibration Of Model 9522NB

The typical A-weighted noise levels are  
sound pressure level: 86 dB (A)

sound power level: 99 dB (A)

– Wear ear protection. –

The typical weighted root mean square acceleration value is not more than 2.5 m/s<sup>2</sup>.

### EC-DECLARATION OF CONFORMITY

The undersigned, Yasuhiko Kanzaki, authorized by Makita Corporation, 3-11-8 Sumiyoshi-Cho, Anjo, Aichi, 446 Japan declares that this product

(Serial No. : series production)

manufactured by Makita Corporation in Japan is in compliance with the following standards or standardized documents,

HD400, EN50144, EN55014, EN61000\*  
in accordance with Council Directives, 73/23/EEC, 89/336/EEC and 98/37/EC.

\*from 1st Jan. 2001

Yasuhiko Kanzaki **CE 94**



Director

### MAKITA INTERNATIONAL EUROPE LTD.

Michigan Drive, Tongwell, Milton Keynes,  
Bucks MK15 8JD, ENGLAND

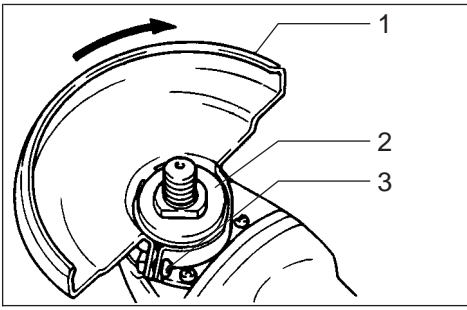

1

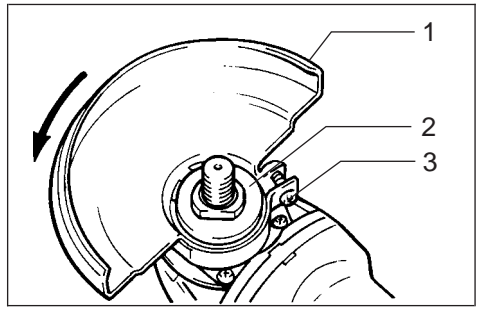

2

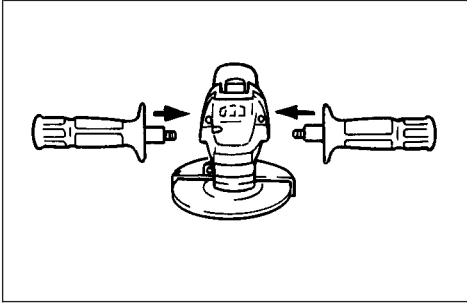

3

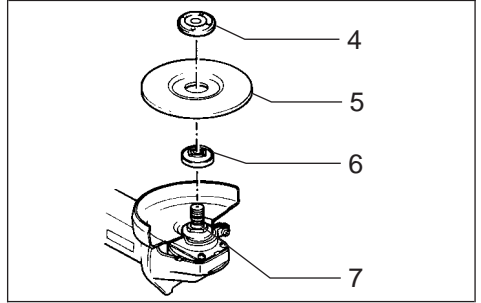

4

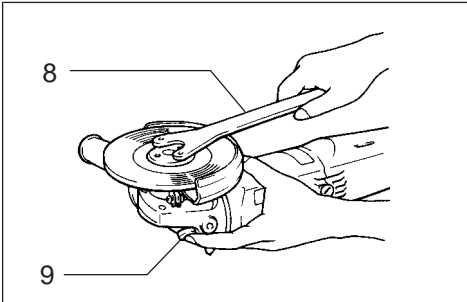

5

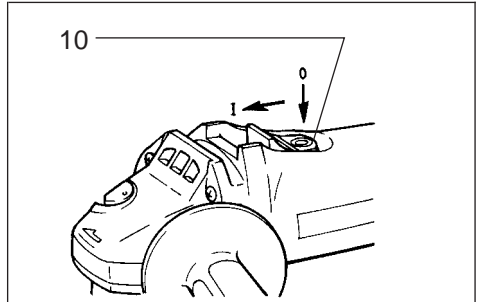

6

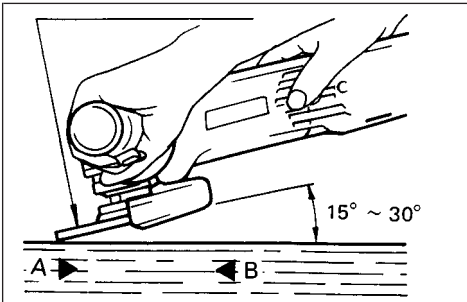

7

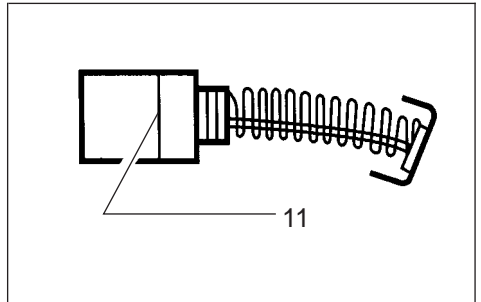

8

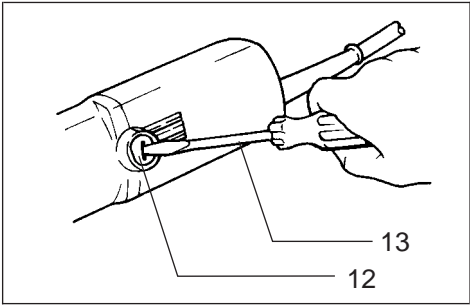

9

## Explanation of general view

1 Wheel guard	6 Inner flange	10 Switch lever
2 Bearing box	7 Spindle	11 Limit mark
3 Screw	8 Lock nut wrench	12 Brush holder cap
4 Lock nut	9 Shaft lock	13 Screwdriver
5 Depressed center wheel		

---

## SAFETY INSTRUCTIONS

**Warning! When using electric tools, basic safety precautions should always be followed to reduce the risk of fire, electric shock and personal injury, including the following.**

**Read all these instructions before attempting to operate this product and save these instructions.**

**For safe operation:**

### 1. Keep work area clean

Cluttered areas and benches invite injuries.

### 2. Consider work area environment

Don't expose power tools to rain. Don't use power tools in damp or wet locations. Keep work area well lit. Don't use power tools in presence of flammable liquids or gases.

### 3. Guard against electric shock

Prevent body contact with grounded surfaces (e.g. pipes, radiators, ranges, refrigerators).

### 4. Keep children away

Do not let visitors contact tool or extension cord. All visitors should be kept away from work area.

### 5. Store idle tools

When not in use, tools should be stored in dry, high, or locked-up place, out of the reach of children.

### 6. Don't force tool

It will do the job better and safer at the rate for which it was intended.

### 7. Use right tool

Don't force small tools or attachments to do the job of a heavy duty tool. Don't use tools for purposes not intended; for example, don't use circular saw for cutting tree limbs or logs.

### 8. Dress properly

Do not wear loose clothing or jewelry. They can be caught in moving parts. Rubber gloves and non-skid footwear are recommended when working outdoors. Wear protective hair covering to contain long hair.

### 9. Use safety glasses and hearing protection

Also use face or dust mask if cutting operation is dusty.

### 10. Connect dust extraction equipment

If devices are provided for the connection of dust extraction and collection facilities, ensure these are connected and properly used.

### 11. Don't abuse cord

Never carry tool by cord or yank it to disconnect it from receptacle. Keep cord from heat, oil and sharp edges.

### 12. Secure work

Use clamps or a vise to hold work. It's safer than using your hand and it frees both hands to operate tool.

### 13. Don't overreach

Keep proper footing and balance at all times.

### 14. Maintain tools with care

Keep tools sharp and clean for better and safer performance. Follow instructions for lubricating and changing accessories. Inspect tool cords periodically and, if damaged, have repaired by authorized service facility. Inspect extension cords periodically and replace if damaged. Keep handles dry, clean and free from oil and grease.

### 15. Disconnect tools

When not in use, before servicing, and when changing accessories such as blades, bits and cutters.

### 16. Remove adjusting keys and wrenches

Form the habit of checking to see that keys and adjusting wrenches are removed from tool before turning it on.

### 17. Avoid unintentional starting

Don't carry plugged-in tool with finger on switch. Be sure switch is off when plugging in.

### 18. Outdoor use extension cords

When tool is used outdoors, use only extension cords intended for use outdoors and so marked.

### 19. Stay alert

Watch what you are doing. Use common sense. Do not operate tool when you are tired.

### 20. Check damaged parts

Before further use of the tool, a guard or other part that is damaged should be carefully checked to determine that it will operate properly and perform its intended function. Check for alignment of moving parts, binding of moving parts, breakage of parts, mounting, and any other conditions that may affect its operation. A guard or other part that is damaged should be properly repaired or replaced by an authorized service center unless otherwise indicated elsewhere in this instruction manual. Have defective switches replaced by and authorized service center. Do not use tool if switch does not turn it on and off.

### 21. Warning

The use of any other accessory or attachment other than recommended in this operating instruction or the catalog may present a risk of personal injury.

### 22. Have your tool repaired by an expert

This electric appliance is in accordance with the relevant safety rules. Repairing of electric appliances may be carried out only by experts otherwise it may cause considerable danger for the user.

## ADDITIONAL SAFETY RULES

ENB038-3

1. Always wear safety goggles and ear protectors during operation.
2. Always be sure that the tool is switched off and unplugged before carrying out any work on the tool.
3. Keep guards in place.
4. Use only wheels with correct size and wheels having a maximum operating speed at least as high as the highest No Load Speed marked on the tool's nameplate. When using depressed center wheels, be sure to use only fiberglass-reinforced wheels.
5. Check the wheel carefully for cracks or damage before operation. Replace cracked or damaged wheel immediately.
6. Observe the instructions of the manufacturer for correct mounting and use of wheels. Handle and store wheels with care.
7. Do not use separate reducing bushings or adaptors to adapt large hole abrasive wheels.
8. Use only flanges specified for this tool.
9. Do not damage the spindle, the flange (especially the installing surface) or the lock nut. Damage to these parts could result in wheel breakage.
10. For tools intended to be fitted with threaded hole wheel, ensure that the thread in the wheel is long enough to accept the spindle length.
11. Before using the tool on an actual workpiece, test run the tool at the highest no load speed for at least 30 seconds in a safe position. Stop immediately if there is any vibration or wobbling that could indicate poor installation or a poorly balanced wheel. Check the tool to determine the cause.
12. Check that the workpiece is properly supported.
13. Hold the tool firmly.
14. Keep hands away from rotating parts.
15. Make sure the wheel is not contacting the workpiece before the switch is turned on.
16. Use the specified surface of the wheel to perform the grinding.
17. Do not use cutting off wheel for side grinding.
18. Watch out for flying sparks. Hold the tool so that sparks fly away from you and other persons or flammable materials.
19. Pay attention that the wheel continues to rotate after the tool is switched off.
20. Do not touch the workpiece immediately after operation; it may be extremely hot and could burn your skin.
21. Position the tool so that the power cord always stays behind the tool during operation.
22. If working place is extremely hot and humid, or badly polluted by conductive dust, use a short-circuit breaker (30 mA) to assure operator safety.
23. Do not use the tool on any materials containing asbestos.

24. Do not use water or grinding lubricant.

## SAVE THESE INSTRUCTIONS.

## OPERATING INSTRUCTIONS

### Installing the wheel guard (Fig. 1 & 2)

Important:

Always be sure that the tool is switched off and unplugged before installing or removing the wheel guard.

Mount the wheel guard with the tab on the wheel guard band aligned with the notch on the bearing box. Then rotate the wheel guard 180° clockwise (for 9520NB) or counterclockwise (for 9521NB and 9522NB). Be sure to tighten the screw securely.

### Side grip (auxiliary handle) (Fig. 3)

#### For 9521NB and 9522NB only

For your own safety, always use the side grip. The side grip can be installed on either side of the tool.

### Installing or removing the depressed center wheel (Fig. 4 & 5)

Important:

Always be sure that the tool is switched off and unplugged before installing or removing the wheel.

Mount the inner flange onto the spindle. Fit the wheel on over the inner flange and screw the lock nut onto the spindle. Press the shaft lock to prevent spindle rotation, then use the lock nut wrench to tighten the lock nut securely.

Warning:

Only actuate the shaft lock when the spindle is not moving.

### Switching ON and OFF (Fig. 6)

CAUTION:

Before plugging in the tool, always check to see that the switch actuates properly and returns to the "OFF" position when the rear of the switch lever is depressed.

To switch on, depress the rear of the switch lever and push it forward. The depress the front of the switch lever to lock it.

To switch off, depress the rear of the switch lever.

### Operation (Fig. 7)

Keep the edge of the wheel or disc at an angle of about 15° – 30° to the workpiece surface. During the break-in period with a new wheel, do not work the tool in the B direction. It will cut into the workpiece. Once the edge of the wheel has been rounded off by use, the wheel may be worked in both A and B directions.

WARNING:

- It should never be necessary to force the tool. The weight of the tool applies adequate pressure. Forcing and excessive pressure could cause dangerous wheel breakage.

- Continued use of a worn-out wheel may result in wheel explosion and serious personal injury. Depressed center wheel should not be used after it has been worn down to 75 mm for Model 9520NB or 90 mm for Models 9521NB and 9522NB in diameter.

## ACCESSORIES

### CAUTION:

These accessories or attachments are recommended for use with your Makita tool specified in this manual. The use of any other accessories or attachments might present a risk of injury to persons. The accessories or attachments should be used only in the proper and intended manner.

- Wheel guard

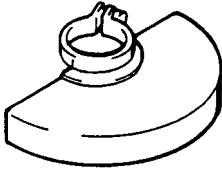

- Depressed center wheel



- Inner flange 40  
(For depressed center wheel)



- Lock nut 40  
(For depressed center wheel)



- Rubber pad

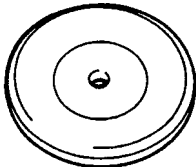

## MAINTENANCE

### CAUTION:

Always be sure that the tool is switched off and unplugged before carrying out any work on the tool.

### Replacement of carbon brushes (Fig. 8 & 9)

Whenever carbon brushes must be replaced, they cut out the tool automatically. When this occurs, replace both carbon brushes at the same time. Use only identical carbon brushes.

To maintain product safety and reliability, repairs, maintenance or adjustment should be carried out by a Makita Authorized Service Center.

- Abrasive disc

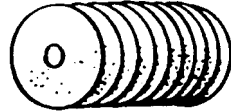

- Lock nut 48  
(For abrasive disc)



- Lock nut wrench



- Grip

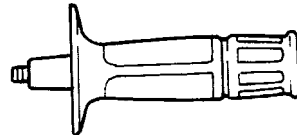

UK only



## THE ADDITIONAL COMMENT OF ELECTRICAL CONNECTION

The tool is double insulated for safety, no earth connection is required.

**CAUTION:** The tool must be connected to a plug having a rated current greater than that of tool. The rated voltage and current appear on the name plate.

**IMPORTANT:** The wires in the mains lead are coloured in accordance with the following code.

**BLUE — NEUTRAL**  
**BROWN — LIVE**

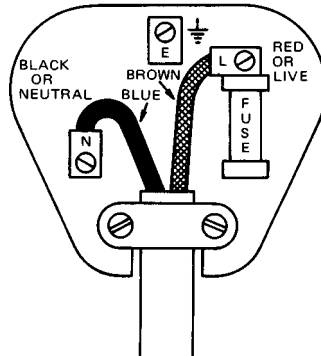

**NOTE:** As the colours of the mains lead of the tool may not correspond with the coloured markings identifying the terminals in your plug, proceed as follows:

THE WIRE WHICH IS COLOURED BLUE MUST BE CONNECTED TO THE TERMINAL WHICH IS MARKED WITH THE LETTER "N" OR COLOURED BLACK. THE WIRE WHICH IS COLOURED BROWN MUST BE CONNECTED TO THE TERMINAL WHICH IS MARKED WITH THE LETTER "L" OR COLOURED RED.

**CAUTION:** Neither wire is to be connected to earth terminal which is marked with the letter "E" or symbol "⏏".

FOR 110 VOLT TOOL, USE PLUGS TO BS4343.

# Makita Corporation

Anjo, Aichi Japan

Made in Japan

883893-224